

Color mark sensor



Operating Instructions

CAUTIONS AND WARNINGS

SET-UP DISTANCE ADJUSTMENT:

As a general rule, the sensor should be fixed at a 15° to 20° angle from directly perpendicular to the target surface. This will prevent direct reflected signal from glossy surfaces.

To obtain maximum tolerance to distance variation, place the target at the greatest distance it is likely to be in the application, for example, flat against a guide surface. Carefully adjust the sensor distance to obtain the highest reading on the white background and note the reading. Now move it slightly further away, to get approximately 5% lower reading and fix sensor at that distance. This will allow the target to move closer, back to the highest reading, then closer still down to 5% lower. The result should be a minimum of 2mm of allowable flutter with <5% change in reading.

CAUTION: The discrete output must not be connected to outputs from other sensors (i.e. outputs from multiple sensors must not be connected in parallel). Parallel connections may damage sensor output circuitry.

IMPORTANT:

This product is an accessory or part of a system. Always read and follow the manufacturer's instructions for the equipment before connecting this product. Comply with all applicable codes and safety regulations. Failure to do so may result in damage, injury or death.

CERTIFICATIONS: ETL, CE, CSA

ETL, CE and CSA certifications are in process.

PRODUCT OVERVIEW

The CMYX sensor combines small spot size and fast response to achieve high-speed color mark detection capable of detecting standard one-track PHARMA-CODE (0.5mm thin bar width). The CMYX effectively detects any color mark printed on a white background. The modulated white light source in the CMYX is focused to a pinpoint and directed toward a target. The diffused light returning to the sensor is measured. When the level drops to the threshold the discrete output changes state. Due to the fast response of the sensor, it is suitable for use in high-speed applications. The sensor provides a discrete output that automatically configures to NPN and PNP. A PLC or a computer can be used to monitor the status of the discrete output signal indicating the presence of a color mark.

The CMYX is a reliable, compact sensor with high-speed sensing capabilities. Two seven segment displays provide visual representation of the relative intensity from 00 to 99. The calibration feature and 3 LED intensity settings provide for flexible operation over a wide range of colors.

Specifications

White light source	Broad spectrum LED, min.100,000 hours
Sensing distance	26mm
Spot size (dia.)	0.4mm
Distance variation sensitivity	<3% @ +/-1mm from focal point
Response time	25uS
Switching Frequency	40kHz
LED Intensity	3 levels
Relative intensity display range	00 to 99
Sensitivity	Adjustable
Signal level	Two 7 segment digits
Detection threshold	Two 7 segment digits
Digital Output	Auto-Detect PNP / NPN
Output Function	NO/NC selectable
Security	LOCK / UN-LOCK keypad
Power indicator	Green LED
Detect indicator	Red LED
Programming indicator	Yellow LED
Data retention	EEPROM non-volatile memory
Dimensions	2.0"(51mm) x 2.4"(61mm) x 1.0"(25mm)
Weight	0.21 lbs. (95 g)
Supply Voltage	10...24 VDC
Operating Current	60 mA
Short Circuit Protection	Discrete output
Overload / Reverse Polarity Protection	Supply voltage
Operating temperature	-20°C...55°C
Storage temperature	-20°C...70°C
Housing	Metal alloy
Mechanical protection	IP65 NOT FOR PRESSURE WASHDOWN

QUICKSTART GUIDE

1. The display range is 00 through 99. The decimal points indicate the LED intensity level. The RED LED above the display indicates that the intensity level drops below the threshold setting.
2. Connect cable to power supply observing correct polarity. Reference wiring diagram.
3. Apply power; sensor will initialize and perform its power up sequence.
4. To obtain maximum tolerance to distance variation, place the target at the greatest distance it is likely to be in the application, for example, flat against a guide surface. Carefully adjust the sensor distance to obtain the highest reading on the white background and note the reading. Now move the sensor slightly further away, to get approximately 5% lower reading and fix sensor at that distance. This will allow the target to move closer, back to the highest reading, then closer still down to 5% lower. The result should be a minimum of 2mm of allowable flutter with <5% change in reading.
5. Place a sample (see back cover of this manual) with white background into the sensor spot and note the reading, move the sample to the lightest color mark that the sensor will encounter and note the reading. Set the threshold between these 2 values.
6. Various adjustments may be made to increase or decrease sensitivity; refer to the Sections Calibration Adjustment and LED Intensity Level. Refer to Section: Threshold, to alter threshold setting.
7. User programmable parameters are discussed in detail in the following sections.

OPERATION

Power up

Upon power up, the sensor initializes by turning on all segments on the display and sequencing through red, yellow and green on the status LED located above the display.

Intensity display mode

During normal operation the sensor display will indicate the relative intensity of a target within its field of view. The range of the relative intensity display is 00 through 99. The decimal points on the display indicate the LED output intensity. No decimal points indicate low, one decimal point indicates medium and two decimal points indicate high intensity.

Calibration Adjustment

The calibration feature allows the displayed measurement to be adjusted to the desired value by the user.

Adjusting the measured value:

1. Place target in sensor's field-of-view. The sensor will display the current reading.
2. Press either key (for less than 3 seconds); while the current reading is displayed the value is flashed slowly indicating that the sensor is in the adjustment mode.
3. Press T/+ to increment the reading and P/- to decrement the reading.
4. Stop pressing either key and the sensor returns to normal operating mode in 3 seconds.

Note:

- While adjusting the reading, when a limit is reached the display flashes at a faster rate.
- The selected gain is stored in memory and is retained when power is removed.

Local Lock

The local lock feature allows the sensor to be locked out, preventing adjustments by unauthorized personnel. To lock the sensor, press the **P/-** and **T/+** buttons for 3 seconds until **LL** is displayed. To un-lock the sensor, press the **T/+** and **P/-** for 3 seconds until **LL** is not displayed. While the sensor is locked, pressing either **P/-** or **T/+** will result in **LL** (Local Lock) indication on the display.

Programmable Parameters

All adjustments made to these parameters are stored in memory and are retained when power is removed. To enter programming mode press and hold the **P/-** key for several seconds, the current threshold setting will be displayed. Press and release the **P/-** key to scroll through the various settings. Press and release the **T/+** key to change a particular setting. Press and hold the **P/-** for several seconds to return to the normal intensity display mode. The user programmable items are described below.

Threshold

When the relative intensity level drops to the threshold setting or lower, the red status LED will turn on and the discrete output will activate, indicating detection of the mark. When the relative intensity level returns above the threshold (as determined by the hysteresis setting), the red LED will extinguish and the discrete output will de-activate. The threshold setting allows the user to select the level at which a mark will be detected. The default setting is 30.

To adjust the threshold, enter programming mode, press and hold the **P/-** key for several seconds, the current threshold setting will be displayed. Press and release the **T/+** key to increase the threshold level, to decrease the threshold level, continue to hold the **T/+** key until the value approaches 99 then wraps around to 00.

LED Intensity Level (U)

The LED intensity is indicated on the display as U1, U2 and U3 for low, medium and high intensity. Press and release the **T/+** key to toggle through the 3 intensity levels. The default setting is U2, medium intensity.

Hysteresis Level (H)

The hysteresis setting is indicated by H0 through H9. The hysteresis level is how far above the threshold the signal increase to de-activate or un-detect. The hysteresis can be set from 0 to 9. For example, if the threshold is set at 25 and the drops to 25 or lower, the sensor will detect and activate its output. With the hysteresis set to 4, the signal must increase to 30 to un-detect. This feature is useful in cases where there may be variation within a target that might cause the intensity to increase above the threshold slightly; the hysteresis allows the output to remain activated until the level increases significantly. Press and release the **T/+** key to change the hysteresis setting. The default setting is 2.

Discrete Output Configuration

This setting allows the user to select either normal open (no) or normally closed (nc) configuration. The normally open configuration de-activates the output during normal un-detect operation, and activates the output upon detect. The normally closed configuration activates the output during normal un-detect operation, and de-activates the output upon detect. Press and release the **T/+** key to toggle through the selections. Default is normally open.

Null Offset (nu)

NOTE: Always perform the null function when changing LED intensities. The null feature allows the sensor to be “zeroed”. Aim the sensor away from any target, press and hold the **T/+** key to null the sensor. The display will flash the value that is being subtracted.

Teach Function

The teach function allows the user to set the threshold by placing a representative target located at the required distance and allowing the sensor to determine the optimum LED intensity and setting of the threshold level.

SELECT TWO LOCATIONS ON THE SAMPLE: The sensor will set a threshold point between the two locations on the sample that are positioned in front of the sensor in step 2 and 3 below. Examine the sample and determine the two locations on the sample that will be used to teach the sensor.

Step 2 must always be the lighter of the two locations. For example, to detect any color marks on a white paper, use the white paper in step 2 and the lightest mark in step 3. This will allow the sensor to set a threshold between the white and the lightest mark thereby allowing all darker marks to be detected.

1. Press and hold the **T/+** key for several seconds until the yellow led flashes.
2. Place the lightest area of the sample at the appropriate distance from the sensor and press the **P/-** key. The display will flash 3 times and the sensor will adjust the LED intensity level to achieve reasonable signal level. The green LED will flash.
3. Place the darker area of the sample in the sensor’s light spot and press the **P/-** key. The display will flash 3 times.
4. Exit the teach function and return to the normal operating mode by Pressing the **T/+** key for several seconds.

Use the normally open (NO) and normally closed (NC) feature in the set-up menu to set the output logic when necessary (refer to the Discrete Output Configuration section for details).

When in the teach mode the LED flashes constantly, yellow, green or red. Yellow indicates that the sensor is ready to be taught the Detect level. Green indicates that the sensor is ready to be taught the Undetect level. Red indicates that the last attempt to teach resulted in an error. If the error occurred during the teaching of the Detect level then the signal intensity was less than 01. If the error occurred during the teaching of the Undetect level, then the signal intensity was greater than or equal to the threshold level. In either case, repeat the teach function to properly set the levels.

Output Signals

Discrete Output

The discrete output is a PNP/NPN configuration allowing the user to provide a load on this output that is either pulled high to VDC or low to ground. The sensor monitors this level and automatically determines whether to operate the PNP/NPN driver. This output is typically connected to a PLC. The output remains active as long as the intensity level exceeds the threshold, in high-speed applications it may be useful to use the Extend Output Pulse feature to lengthen the signal duration to meet acquisition requirements of the PLC.

CAUTION: The discrete output must not be connected to outputs from other sensors (i.e. outputs from multiple sensors must not be connected in parallel). Parallel connections may damage sensor output circuitry.

Remote Lock/Unlock Input

The remote lock feature allows the user to lock out the local controls (keys) to prevent operators from making unauthorized adjustments. This signal line must be connected to VDC to lock the sensor. This line may be left unconnected if the lock feature is not used. While the sensor is locked, pressing either **P/-** or **T/+** will result in **rL** (remote Lock) indication on the display.

Sensor-to-target distance variation

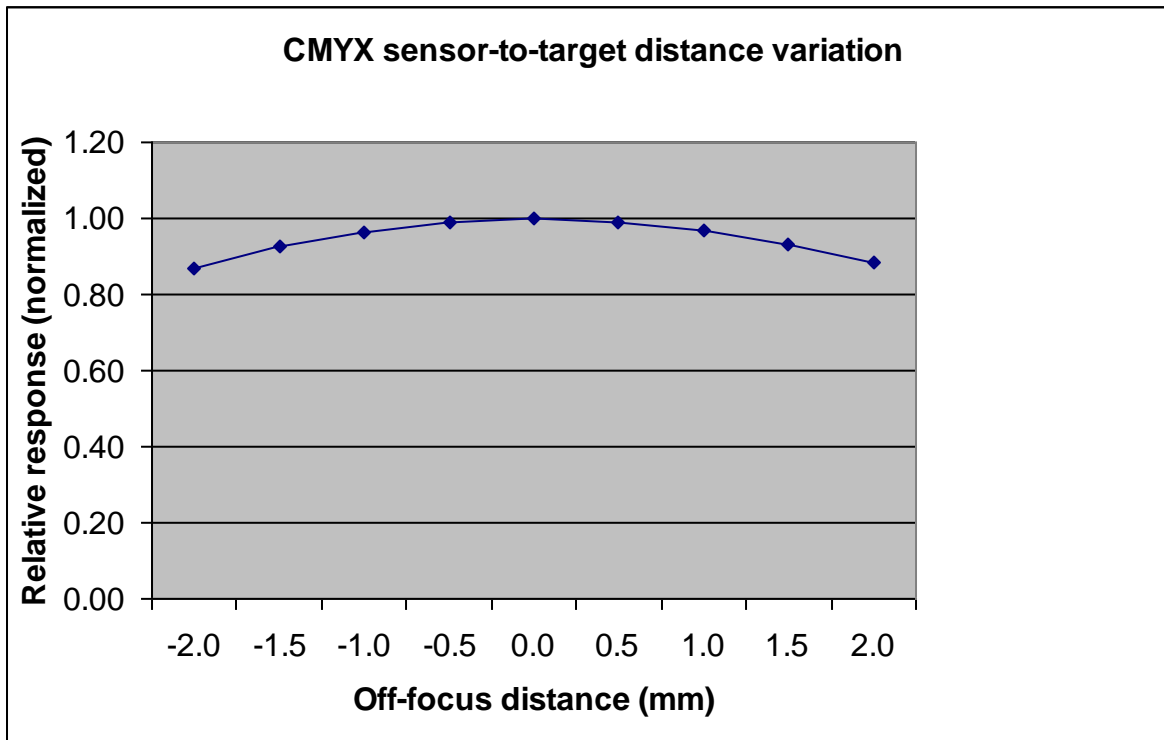

Display Indicators

Indicators

- Green LED Threshold Mode while in Undetect
- Red LED Detect
- Yellow LED Threshold Mode while in Detect

Display decimal points

- None illuminated LED low intensity
- One illuminated LED medium intensity
- Two illuminated LED high intensity

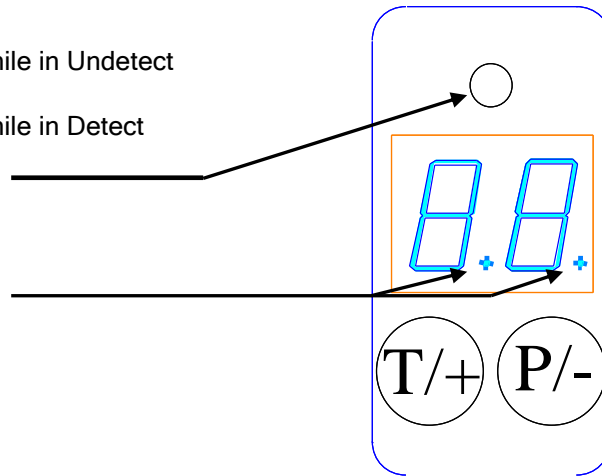

M12 connector pin assignments

M12 Connector	Wire Color	Description
Pin 1	Brown	Power 10 to 24VDC
Pin 2	White	Discrete output, PNP/NPN, NO/NC
Pin 3	Blue	Ground
Pin 4	Black	Unused
Pin 5	Yellow	Remote lock

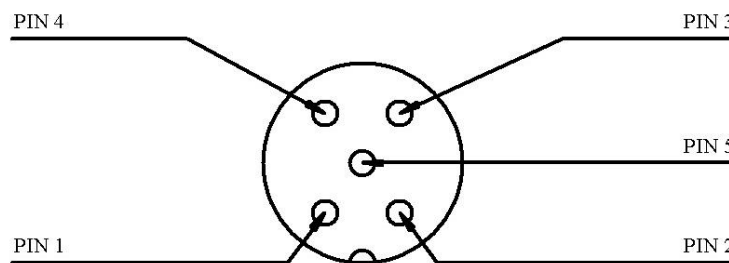

Ordering information

CMYX-05-0 Color mark sensor

Accessories



UVX300-BRKT
Bracket



UVX 300-C
5 meter cable with M12
5-pin connector

Dimensional Details

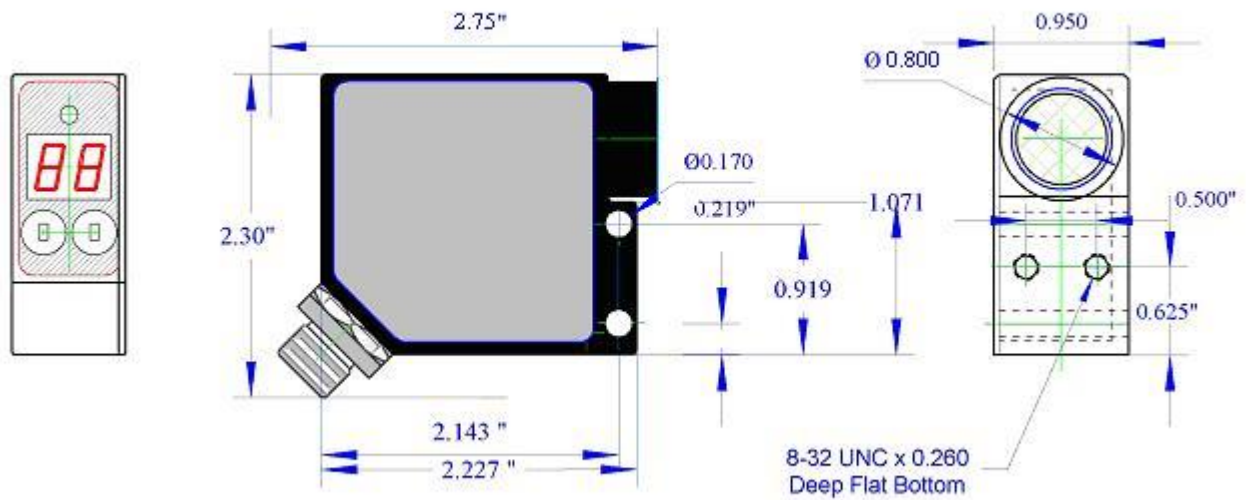

Sensor I/O Connections

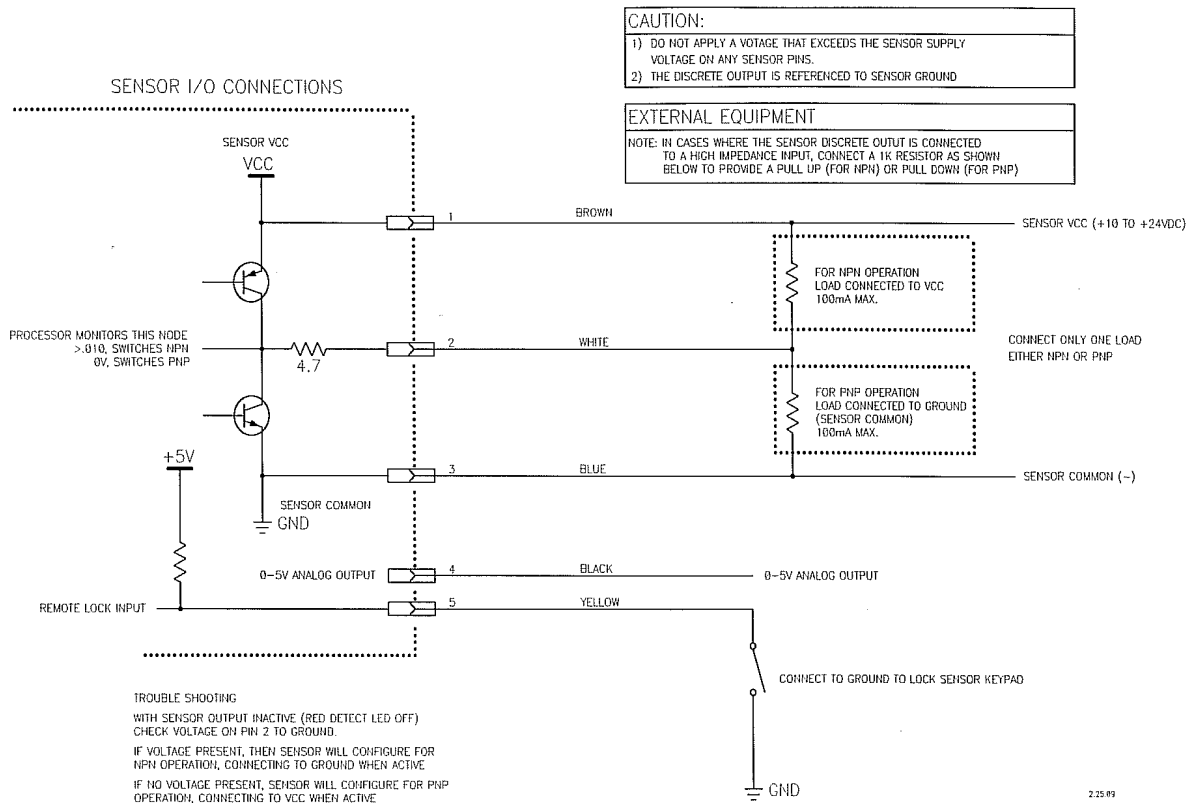

WARRANTY

EMX Industries Incorporated warrants all products to be free of defects in materials and workmanship for a period of two years under normal use and service from the date of sale to our customer. This warranty does not cover normal wear and tear, abuse, misuse, overloading, altered products, damage caused by incorrect connections, lightning damage, or use other than intended design.

There is no warranty of merchantability. There are no warranties expressed or implied or any affirmation of fact or representation except as set forth herein.

EMX Industries Inc. sole responsibility and liability, and the purchaser's exclusive remedy shall be limited to the repair or replacement at EMX Industries option of a part or parts found not conforming to the warranty. In no event shall EMX Industries Inc. be liable for damages of any nature, including incidental or consequential damages, including but not limited to damages resulting from non-conformity, defect in material or workmanship.

effective date January 1, 2002





4564 Johnston Parkway
Cleveland, Ohio 44128
United States of America
WEB <http://www.emxinc.com>

Technical Support: (216) 834-0761
E-mail: technical@emxinc.com

Sales: (216) 518-9888
Fax (216) 518-9884
E-mail salesupport@emxinc.com



CMYX test pattern

Revision 1.4
7.30.13