



UVX-300P

INCLUDES UVX-300P-FG

Phosphorescence sensor



Operating Instructions

CAUTIONS AND WARNINGS

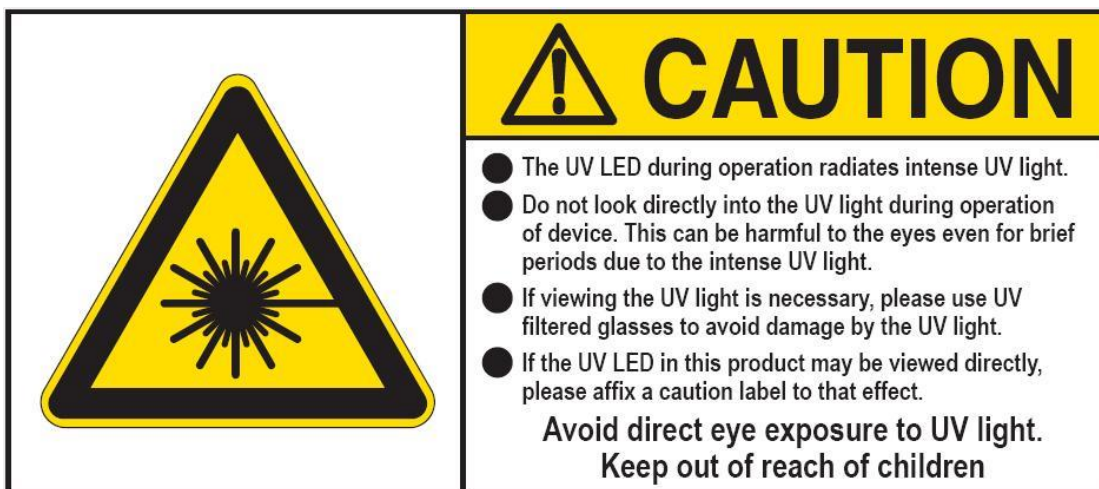

CAUTION: The discrete output must not be connected to outputs from other sensors (i.e. outputs from multiple sensors must not be connected in parallel). Parallel connections may damage sensor output circuitry.

IMPORTANT:

This product is an accessory or part of a system. Always read and follow the manufacturer's instructions for the equipment before connecting this product. Comply with all applicable codes and safety regulations. Failure to do so may result in damage, injury or death.

Langue Française Attention:

- La LED UV rayonne la lumière UV intense lors du fonctionnement.
- N'examinez pas directement la lumière UV lors du fonctionnement de dispositif. Ceci peut être nocif aux yeux, même pour la brève période due à la lumière UV intense.
- Si le visionnement de la lumière UV est nécessaire, employez svp les verres filtrés UV pour éviter des dommages d'oeil par la lumière UV.
- Évitez l'exposition directe d'oeil à la lumière UV.

Substance hors de l'extension des enfants.

CERTIFICATIONS: CE, CSA, UL



PRODUCT OVERVIEW

The UVX-300P sensor effectively detects phosphorescent materials and markers. Model UVX300P-FG is specifically designed to detect phosphorescent materials while suppressing blue fluorescence from optical brighteners commonly found in paper products. Refer to spectral response shown in the Specifications. Since the sensor UV light source is not modulated, the sensor is sensitive to ambient light, therefore, a shroud or low light conditions are necessary for reliable operation. The UV light source in the UVX300P is directed toward a target and the visible light, resulting from the fluorescence of the material, is reflected back to the sensor. When the reflected light level exceeds the threshold, the discrete output changes state. Due to the fast response of the sensor, it is suitable for use in high-speed applications. The 50mm lens accessory allows for very small spot size for fine resolution applications. The sensor provides both an analog and a discrete output. The analog output signal has a 0 to 5 V range with 20mV resolution. A PLC or a computer can be used to process the analog output and monitor the status of the discrete output signal.

The UVX 300P is a reliable, compact sensor with long range sensing capabilities. Two seven segment displays provide visual representation of the relative intensity from 00 to 99. Calibration feature and 3 LED intensity settings provide for flexible operation over wide range of distances and materials.

Specifications

UV light source	370nm UV LED, min.100,000 hours
Light spot size	6..8mm dia. @50mm
Light source intensity	3 levels
Sensing distance	Up to 350mm
Receiver spectral response	350...1000nm
Receiver spectral response (FG model)	500...1000nm
Response time	<150uS
Switching Frequency	6 kHz
Relative Intensity Display Range	00 to 99
Sensitivity	Adjustable
Signal level	Two 7-segment digits
Detection threshold	Two 7-segment digits
Digital Output	Auto-Detect PNP / NPN
Output function	NO/NC selectable
Analog Output	0..5V (20mV resolution)
Power indicator	Green LED
Detect indicator	Red LED
Programming indicator	Yellow LED
Data retention	EEPROM non-volatile memory
Dimensions	51mm x 61mm x 25mm (2.0" x 2.4" x 1.0")
Weight	95g (0.21 lbs.)
Supply voltage	10...24 VDC
Operating current	60 mA
Short circuit protection	Discrete outputs
Overload / reverse polarity protection	Supply voltage
Operating temperature	-20°C...55°C
Storage temperature	-20°C...70°C
Housing	Metal alloy
Mechanical protection	IP65 NOT FOR PRESURE WASHDOWN

QUICKSTART GUIDE

1. The display range is 00 through 99. The decimal points indicate the LED intensity level. The RED LED above the display indicates that the intensity level exceeds the threshold setting.
2. Connect cable to power supply observing correct polarity. Reference wiring diagram.
3. Apply power; sensor will initialize and perform its power up sequence.
4. The relative intensity will be displayed. By aiming the sensor away from any objects the display will indicate 00. Aim the sensor at a target and the display will indicate an intensity measurement. Move the paper further away from the sensor to decrease the intensity level.
5. Various adjustments may be made to increase or decrease sensitivity; refer to the Selections Calibration Adjustment and LED Intensity Level. Refer to Section: Threshold, to after threshold setting.
6. User programmable parameters are discussed in detail in the following sections.

OPERATION

Power up

Upon power up, the sensor initializes by turning on all segments on the display and sequencing through red, yellow and green on the status LED located above the display.

Intensity display mode

During normal operation the sensor display will indicate the relative intensity of a target within its field of view. The range of the relative intensity display is 00 through 99. The decimal points on the display indicate the LED output intensity. No decimal points indicate low, one decimal point indicates medium and two decimal points indicate high intensity.

Calibration Adjustment

The calibration feature allows the displayed measurement to be adjusted to the desired value by the user.

Adjusting the measured value:

1. Place target in sensor's field-of-view. The sensor will display the current reading.
2. Press either key (for less than 3 seconds); while the current reading is displayed the value is flashed slowly indicating that the sensor is in the adjustment mode.
3. Press T/+ to increment the reading and P/- to decrement the reading.
4. Stop pressing either key and sensor returns to normal operating mode in 3 seconds.

Note:

- While adjusting the reading, when a limit is reached the display flashes at a faster rate.
- The selected gain is stored in memory and is retained when power is removed.

Local Lock

The local lock feature allows the sensor to be locked out, preventing adjustments by unauthorized personnel. To lock the sensor, press the P/- and T/+ buttons for 3 seconds until LL is displayed. To un-lock the sensor, press the T/+ and P/- for 3 seconds until LL is not displayed. While the sensor is locked, pressing either P/- or T/+ will result in LL (Local Lock) indication on the display.

Programmable Parameters

All adjustments made to these parameters are stored in memory and are retained when power is removed. To enter programming mode press and hold the **P/-** key for several seconds, the current threshold setting will be displayed. Press and release the **P/-** key to scroll through the various settings. Press and release the **T/+** key to change a particular setting. Press and hold the **P/-** for several seconds to return to the normal intensity display mode. The user programmable items are described below.

Threshold

When the relative intensity level exceeds the threshold setting the red status LED will turn on and the discrete output will activate, indicating detection of the target. When the relative intensity level drops below the threshold (as determined by the hysteresis setting), the red LED will extinguish and the discrete output will de-activate. The threshold setting allows the user to select the detection level. The default setting is 15.

To adjust the threshold, enter programming mode, press and hold the **P/-** key for several seconds, the current threshold setting will be displayed. Press and release the **T/+** key to increase the threshold level, to decrease the threshold level, continue to hold the **T/+** key until the value approaches 99 then wraps around to 00.

LED Intensity Level (U)

The LED intensity is indicated on the display as U1, U2 and U3 for low, medium and high intensity. Press and release the **T/+** key to toggle through the 3 intensity levels. The default setting is U2, medium intensity.

Hysteresis Level (H)

The hysteresis setting is indicated by H0 through H9. The hysteresis level is how far below the threshold the signal must fall to de-activate or un-detect. The hysteresis can be set from 0 to 9. For example, if the threshold is set at 25 and the intensity exceeds 25, the sensor will detect and activate its output. With the hysteresis set to 5, the signal must drop to 20 to un-detect. This feature is useful in cases where there may be variation within a target that might cause the intensity to drop below the threshold slightly; the hysteresis allows the output to remain activated until the level drops significantly. Press and release the **T/+** key to change the hysteresis setting. The default setting is 2.

Discrete Output Configuration

This setting allows the user to select either normal open (no) or normally closed (nc) configuration. The normally open configuration de-activates the output during normal un-detect operation, and activates the output upon detect. The normally closed configuration activates the output during normal un-detect operation, and de-activates the output upon detect. Press and release the **T/+** key to toggle through the selections. Default is normally open.

Extend Output Pulse (P)

This feature allows extending the minimum length of time that the discrete output remains active following target detection. The sensor response can be in the 100uS (microsecond) range, i.e. a target can move through the sensing range in 100uS and the discrete output would active for only that duration. A slower acquisition system (PLC) may not sample its inputs at a fast enough rate to capture the signal. The discrete output pulse can be extended from 0 to 90mS (milliseconds) in 10 mS increments as indicated by P0 though P9 on the display. Press and release the **T/+** key to toggle through the selections.

Null Offset (nu)

NOTE: Always perform the null function when installing or removing optional lens or changing LED intensities.

The null feature allows the sensor to be “zeroed”. For example, when the target is not in view and there is a background that causes a reading above zero, the null feature allows this level to be subtracted out, allowing the display to indicate 00. Press and hold the **T/+** key to null the sensor. The display will flash the value that is being subtracted. To set the sensor back to a true zero, aim the sensor away from any target and repeat the null process.

Teach Function

The teach function allows the user to set the threshold by placing a representative target located at the required distance and allowing the sensor to determine the optimum LED intensity and setting of the threshold level.

1. Press and hold the **T/+** key for several seconds until the yellow led flashes.
2. Place the target at the appropriate distance from the sensor and press the **P/-** key. The display will flash 3 times and the sensor will adjust the LED intensity level to achieve reasonable signal level. The green LED will flash.
3. Remove the target and press the **P/-** key. The display will flash 3 times.
4. Exit the teach function and return to the normal operating mode by Pressing the **T/+** key for several seconds.

When in the teach mode the LED flashes constantly, yellow, green or red. Yellow indicates that the sensor is ready to be taught the Detect level. Green indicates that the sensor is ready to be taught the Undetect level. Red indicates that the last attempt to teach resulted in an error. If the error occurred during the teaching of the Detect level then the signal intensity was less than 01. If the error occurred during the teaching of the Undetect level, then the signal intensity was greater than or equal to the threshold level. In either case, repeat the teach function to properly set the levels.

Output Signals

Discrete Output

The discrete output is a PNP/NPN configuration allowing the user to provide a load on this output that is either pulled high to VDC or low to ground. The sensor monitors this level and automatically determines whether to operate the PNP/NPN driver. This output is typically connected to a PLC. The output remains active as long as the intensity level exceeds the threshold, in high-speed applications it may be useful to use the Extend Output Pulse feature to lengthen the signal duration to meet acquisition requirements of the PLC.

CAUTION: The discrete output must not be connected to outputs from other sensors (i.e. outputs from multiple sensors must not be connected in parallel). Parallel connections may damage sensor output circuitry.

Analog Output

The analog output is 0-5V with 20mV resolution (8-bit). Any standard analog input channel typically available on a PLC may monitor this output. The analog output signal is useful in applications where simply triggering on the threshold is insufficient. For example, constant real-time monitoring of intensity in process allows minor fluctuations or trends to be detected permitting corrective action to be taken.

Remote Lock/Unlock Input

The remote lock feature allows the user to lock out the local controls (keys) to prevent operators from making unauthorized adjustments. This signal line must be connected to VDC to lock the sensor. This line may be left unconnected if the lock feature is not used. While the sensor is locked, pressing either **P/-** or **T/+** will result in **rL** (remote Lock) indication on the display.

Display Indicators

Indicators

- Green LED Threshold Mode while in Undetect
- Red LED Detect
- Yellow LED Threshold Mode while in Detect

Display decimal points

- None illuminated LED low intensity
- One illuminated LED medium intensity
- Two illuminated LED high intensity

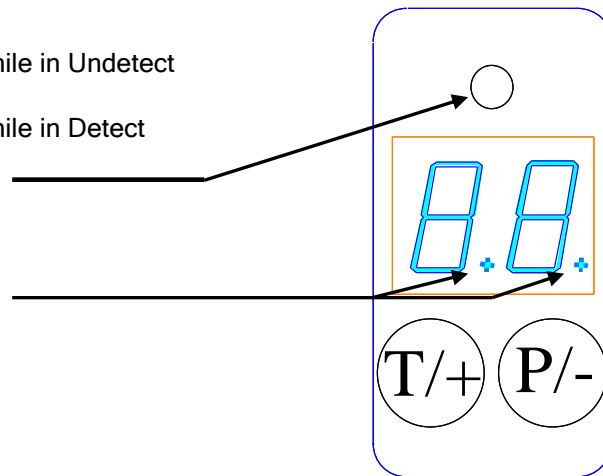

M12 connector pin assignments

M12 Connector	Wire Color	Description
Pin 1	Brown	Power 10 to 24VDC
Pin 2	White	Discrete output, PNP/NPN, NO/NC
Pin 3	Blue	Ground
Pin 4	Black	Analog output 0 to 5V DC
Pin 5	Yellow	Remote Lock (connect to sensor V+)

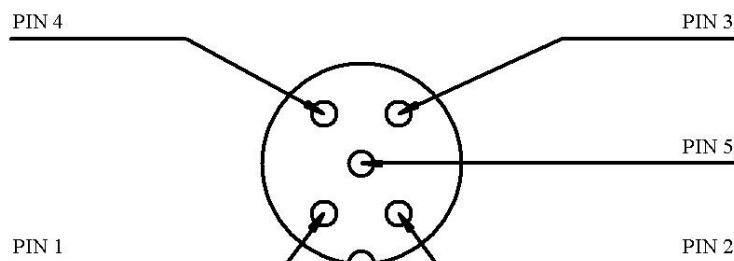

Ordering information

UVX300P
UVX300P-FG

Phosphorescence sensor
Phosphorescence sensor, for use with yellow/green/ red pigment

Accessories

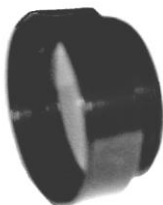

UVX 300-L50
50mm focal lens



UVX300-BRKT
Bracket



UVX 300-C
5 meter cable with M12
5-pin connector

Mounting UVX-300-L50 Focal lens

The focal lens is mounted by screwing the collar into the sensors standard lens collar. An anti-vibration material is present on the focal lens threads. If necessary, use soft cloth with pliers to remove.

Dimensional Details

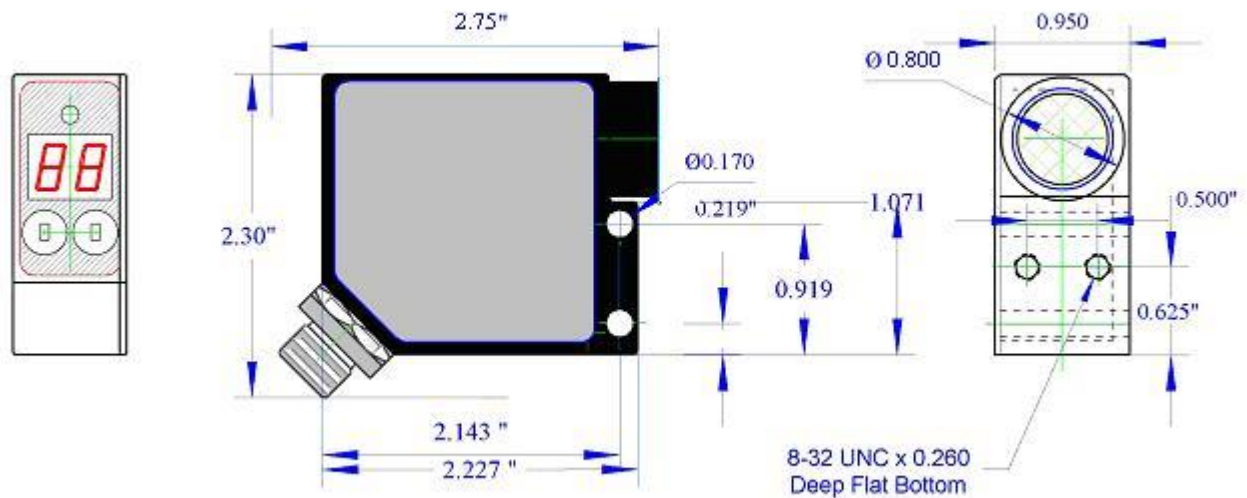

Warranty

WARRANTY

EMX Industries Incorporated warrants all products to be free of defects in materials and workmanship for a period of two years under normal use and service from the date of sale to our customer. This warranty does not cover normal wear and tear, abuse, misuse, overloading, altered products, damage caused by incorrect connections, lightning damage, or use other than intended design.

There is no warranty of merchantability. There are no warranties expressed or implied or any affirmation of fact or representation except as set forth herein.

EMX Industries Inc. sole responsibility and liability, and the purchaser's exclusive remedy shall be limited to the repair or replacement at EMX Industries option of a part or parts found not conforming to the warranty. In no event shall EMX Industries Inc. be liable for damages of any nature, including incidental or consequential damages, including but not limited to damages resulting from non-conformity, defect in material or workmanship.

effective date January 1, 2002



EMX

INDUSTRIES, INC.

4564 Johnston Parkway
Cleveland, Ohio 44128
United States of America
WEB <http://www.emxinc.com>

Technical Support: (216) 834-0761
E-mail: technical@emxinc.com

Sales: (216) 518-9888
Fax (216) 518-9884
E-mail salesupport@emxinc.com

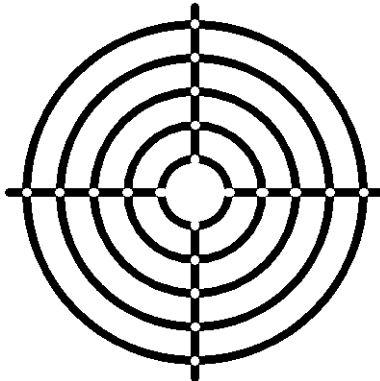

Demonstration target for UVX 300P

Revision 1.0
9.17.14