

UVX-TIN-SIDE

Tin-Side Detection System



4564 Johnston Parkway, Cleveland, Ohio 44128

P. 800 426 9912 F. 216 518 9884

Sales Inquiries: salesupport@emxinc.com

Technical Support: technical@emxinc.com

www.emxinc.com

Cautions and Warnings

| | |
|---|---|
|  |  |
| | <ul style="list-style-type: none">● The UV LED during operation radiates intense UV light.● Do not look directly into the UV light during operation of device. This can be harmful to the eyes even for brief periods due to the intense UV light.● If viewing the UV light is necessary, please use UV filtered glasses to avoid damage by the UV light.● If the UV LED in this product may be viewed directly, please affix a caution label to that effect. <p>Avoid direct eye exposure to UV light. Keep out of reach of children</p> |

CAUTION: The discrete output must not be connected to outputs from other sensors (i.e. outputs from multiple sensors must not be connected in parallel). Parallel connections may damage sensor output circuitry.

BEFORE APPLYING POWER:

The UV LED “on” time is controlled by the user and should be minimized as described in this Instruction to achieve maximum life. For this reason, the LED is not covered by the manufacturer’s warranty.

Connect an earth ground to the stud on the Optical Unit using minimum 20 AWG wire.

IMPORTANT:

This product is an accessory or part of a system. Always read and follow the manufacturer’s instructions for the equipment before connecting this product. Comply with all applicable codes and safety regulations. Failure to do so may result in damage, injury or death.

Certifications

Pending

Product Overview

The UVX tin-side detection system employs our field-proven, UVX™ - based sensor, to accommodate the special requirements for reliable tin-side glass detection. The system consists of a Control Unit, Optical Unit, 24VDC power supply and interface cable.

The Control Unit provides a display with a 00-99 range and access to set-up parameters and threshold adjustment. The output of the Control Unit is a discrete, NPN/PNP that indicates when the signal level exceeds the threshold setting which occurs when viewing the tin-side. The Control unit may be mounted to provide easy access to the controls and the display.

The Optical Unit is mounted at approximately 5-10mm from the surface of the glass. A green LED indicates that the Optical Unit is powered. The enclosure provides 4 mounting holes (or 2 for the UVX tin-side mini) for user-supplied bracket /hardware. The Optical Unit also acts as a shroud over the sampling area to minimize exposure to the UV light source and prevent interference from ambient light. The light source is a special LED with a limited service life. The system employs a remote enable line that allows the user to activate the LED and read the result from the sensor in a short sample period typically 5-10 mS greatly extending the life of the LED.

The system provides both an analog and a discrete output. The analog output signal has a 0 to 5 V range with 20mV resolution. A PLC or a computer can be used to process the analog output and monitor the status of the discrete output signal during the short sample period previously described.

Specifications

| | |
|--|---|
| UV light source | Deep UV LED, typ. 1000 hours continuous |
| Light spot size | 1...2 mm |
| LED Intensity | 3 levels |
| Relative Intensity Display Range | 00...99 |
| Sensitivity | Adjustable |
| Detection Range | 5...10mm |
| Switching Frequency | 6 kHz |
| Brightness level | Two 7 segment digits |
| Brightness threshold | Two 7 segment digits |
| Analog Output | 0...5 V (20mV resolution) |
| Digital Output | Auto-Detect PNP / NPN |
| Extend Output Pulse | 0 - 90 mS (10 steps) |
| Output Function | NO/NC selectable |
| On/Off Delay | <150 uS |
| Security | LOCK / UN-LOCK keypad |
| Power indicator | Green LED |
| Detect indicator | Red LED |
| Programming indicator | Yellow LED |
| Data retention | EEPROM non—volatile memory |
| Supply Voltage | 10-30 VDC |
| Operating Current | 60 mA |
| Short Circuit Protection | Discrete output and analog output |
| Overload / Reverse Polarity Protection | Supply voltage |
| Operating temperature | -20°C...55°C |
| Storage temperature | -20°C...70°C |
| Housing | Metal alloy |
| <hr/> | |
| UVX300G-C-CU (control unit) | |
| Dimensions | 51mm (2.0") x 61mm (2.4") x 25mm (1.0") |
| Weight | 95 g (0.21 lbs.) |
| <hr/> | |
| OU-TS2 (optical unit tin-side mini) | |
| Dimensions | 41mm (1.6") x 86mm (3.38") x 91mm (3.55") |
| Weight | 500 g (1.1 lbs.) |

Operation

Power Up

Upon power up, the sensor initializes by turning on all segments on the display and sequencing through red, yellow and green on the status LED located above the display. The green LED on the Optical Unit indicates power.

Intensity Display Mode

During normal operation the sensor display will indicate the relative intensity of a target within its field of view. The display is useful primarily during set-up and adjustment of the sensor. During normal operation where there is movement of the samples/targets, the display is not generally useful since the display update rate is about 3x/sec. The range of the relative intensity display is 00 through 99. The decimal points on the display indicate the LED output intensity. No decimal points indicate low, one decimal point indicates medium and two decimal points indicate high intensity.

Calibration Adjustment

The calibration feature allows the displayed measurement to be adjusted to the desired value by the user.

Adjusting the measured value:

1. Place target in sensor's field-of-view. The sensor will display the current reading.
2. Press either key (for less than 3 seconds); while the current reading is displayed the value is flashed slowly indicating that the sensor is in the adjustment mode.
3. Press T/+ to increment the reading and P/- to decrement the reading.
4. Stop pressing a key and sensor returns to normal operating mode in 3 seconds.

Note:

- While adjusting the reading, when a limit is reached the display flashes at a faster rate.
- The selected gain is stored in memory and is retained when power is removed.

Local Lock

The local lock feature allows the sensor to be locked out, preventing adjustments by unauthorized personnel. To lock the sensor, press the **P/-** and **T/+** buttons for 3 seconds until **LL** is displayed. To un-lock the sensor, press the **T/+** and **P/-** for 3 seconds until **LL** is not displayed. While the sensor is locked, pressing either **P/-** or **T/+** will result in **LL (Local Lock)** indication on the display.

Programmable Parameters

All adjustments made to these parameters are stored in memory and are retained when power is removed. To enter programming mode press and hold the **P/-** key for several seconds, the current threshold setting will be displayed. Press and release the **P/-** key to scroll through the various settings. Press and release the **T/+** key to change a particular setting. Press and hold the **P/-** for several seconds to return to the normal intensity display mode. The user programmable items are described below.

Threshold

When the relative intensity level exceeds the threshold setting the red status LED will turn on and the discrete output will activate, indicating detection of the target. When the relative intensity level drops below the threshold (as determined by the hysteresis setting), the red LED will extinguish, and the discrete output will de-activate. The threshold setting allows the user to select the detection level. The default setting is 15.

To adjust the threshold, enter programming mode, press and hold the **P/-** key for several seconds, the current threshold setting will be displayed. Press and release the **T/+** key to increase the threshold level, to decrease the threshold level, continue to hold the **T/+** key until the value approaches 99 then wraps around to 00.

LED Intensity Level (U)

The LED intensity is indicated on the display as U1, U2 and U3 for low, medium and high intensity. Press and release the **T/+** key to toggle through the 3 intensity levels. The default setting is U2, medium intensity.

Hysteresis Level (H)

The hysteresis setting is indicated by H0 through H9. The hysteresis level is how far below the threshold the signal must fall to de-activate or un-detect. The hysteresis can be set from 0 to 9. For example, if the threshold is set at 25 and the intensity exceeds 25, the sensor will detect and activate its output. With the hysteresis set to 5, the signal must drop to 20 to un-detect. This feature is useful in cases where there may be variation within a target that might cause the intensity to drop below the threshold slightly; the hysteresis allows the output to remain activated until the level drops significantly. Press and release the **T/+** key to change the hysteresis setting. The default setting is 2.

Discrete Output Configuration

This setting allows the user to select either normal open (no) or normally closed (nc) configuration. The normally open configuration de-activates the output during normal un-detect operation, and activates the output upon detect. The normally closed configuration activates the output during normal un-detect operation, and de-activates the output upon detect. Press and release the **T/+** key to toggle through the selections. Default is normally open

Extend Output Pulse (P)

This feature allows extending the minimum length of time that the discrete output remains active following target detection. The sensor response can be in the 100uS (microsecond) range, i.e. a target can move through the sensing range in 100uS and the discrete output would active for only that duration. A slower acquisition system (PLC) may not sample its inputs at a fast enough rate to capture the signal. The discrete output pulse can be extended from 0 to 90mS (milliseconds) in 10 mS increments as indicated by P0 through P9 on the display. Press and release the **T/+** key to toggle through the selections.

Null Offset (nu)

NOT USED

System Operation

The purpose of the UVX Tin-side detector system is to identify the tin-side of float glass by projecting the UV light source onto the target surface. When the tin-side is present the surface will emit light in the visible spectrum. The receiver optics measures the intensity of the visible light and when the level exceeds the user adjustable threshold setting the discrete output will activate.

The UVX Tin-side detection system is typically controlled by a PLC. Due to the limited service life of the light source it is necessary to use the PLC to initiate and control the measurement process. A typical sequence may be set-up as follows:

1. A separate proximity sensor detects the presence and proper positioning of a sample pane. Its output is connected to the PLC.
2. The PLC activates the UVX LED Enable line by connecting this line to sensor ground.
3. The PLC waits 5-10mS, and then reads the UVX discrete output to determine if the tin-side is present. The PLC deactivates the UVX LED Enable line by disconnecting this line from sensor ground.

Installation

The Optical Unit contains the light source and receiver optics. The unit is to be mounted 5-10mm above the glass surface. During installation be careful not to damage the optics.

1. Read the Caution statements in this manual regarding the UV light source prior to installation.
2. Connect an earth ground to the stud on the Optical Unit using minimum 20 AWG wire.
3. Position the Optical Unit to be parallel to the glass surface at a distance of 5-10mm. For optimum performance, the distance should be adjustable.
4. There should be nothing on the other side of the glass (within 300mm), or the surface should be matte black to minimize reflections from the sensor light source and ambient lighting.
5. The UVX Control Unit may be mounted in an easily accessible area near the Optical Unit to allow adjustments of sensor parameters.
6. Connect the cable between the Optical Unit and the Control Unit.
7. Connect the Control Unit wiring to the power source and PLC. If necessary, connect LED Enable (yellow wire) to sensor ground to activate the light source. Always disconnect the jumper to disable the light source when not in use.
8. Use a piece of white paper on the glass to visually verify that the light source is on. The optical brighteners in the paper will produce a bright blue light spot.
9. Remove the paper and slide a glass sample, with the tin-side toward the Optical Unit, into position.
10. The display will indicate the signal level due to the interaction between the UV light and tin-side surface which produces visible light. Adjust the distance between the Optical Unit and the glass surface to obtain the highest reading.
11. Remove the glass and place the air-side toward the Optical Unit. The reading should be much lower than that of the tin-side. Adjust the threshold to the value between these two readings.
12. Remove the jumper and test the system.

Discrete Output

The discrete output is a PNP/NPN configuration allowing the user to provide a load on this output that is either pulled high to VDC or low to ground. The sensor monitors this level and automatically determines whether to operate the PNP/NPN driver. This output is typically connected to a PLC. The output remains active as long as the intensity level exceeds the threshold, in high-speed applications it may be useful to use the Extend Output Pulse feature to lengthen the signal duration to meet acquisition requirements of the PLC.

CAUTION: The discrete output must not be connected to outputs from other sensors (i.e. outputs from multiple sensors must not be connected in parallel). Parallel connections may damage sensor output circuitry.

Analog Output

The analog output is 0-5V with 20mV resolution (8-bit). Any standard analog input channel typically available on a PLC may monitor this output. The analog output signal is useful in applications where simply triggering on the threshold is insufficient. For example, constant real-time monitoring of intensity in process allows minor fluctuations or trends to be detected permitting corrective action to be taken.

LED Enable

The LED Enable feature allows the user to activate the LED only when a measurement is necessary, minimizing the on time of the LED and extending its service life.

IMPORTANT:

This line is to be left open to disable the light source; the light source should be disabled at all times other than the short cycle required to make a measurement.

It is recommended that the typical measurement cycle be limited to 5-10mS (milliseconds).

Display Indicators

Indicators

- Green LED Threshold Mode while in Undetect
- Red LED Detect
- Yellow LED Threshold Mode while in Detect

Display decimal points

- None illuminated LED low intensity
- One illuminated LED medium intensity
- Two illuminated LED high intensity

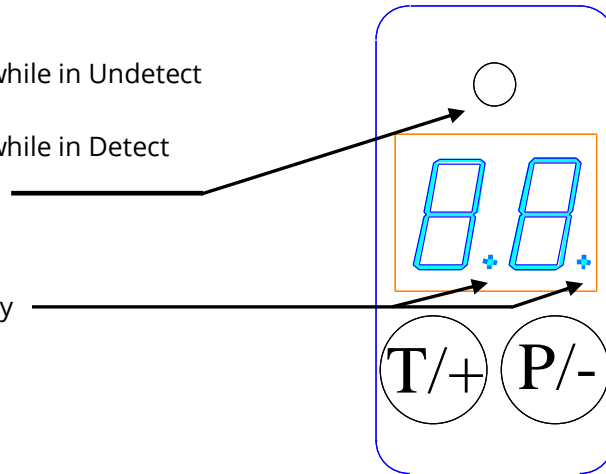

M12 Connector Pin Assignments

| M12 Connector | Wire Color | Description |
|---------------|------------|---------------------------------|
| Pin 1 | Brown | Power 10 to 24VDC |
| Pin 2 | White | Discrete output, PNP/NPN, NO/NC |
| Pin 3 | Blue | Ground |
| Pin 4 | Black | Analog output 0 to 5V DC |
| Pin 5 | Yellow | LED enable (ground to enable) |

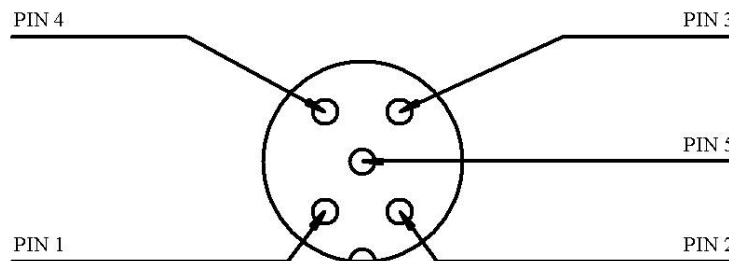

Ordering Information

UVX -300G-C-CU
OU-TS2
M12-10-2-MF
240-240025

Control Unit
Optical Unit
Cable, 10P, 5M, M12, M/F
Power supply, 24VDC regulated

Accessories



UVX300-BRKT
Bracket



UVX 300-C
5 meter cable with M12
5-pin connector

Mounting Dimensions

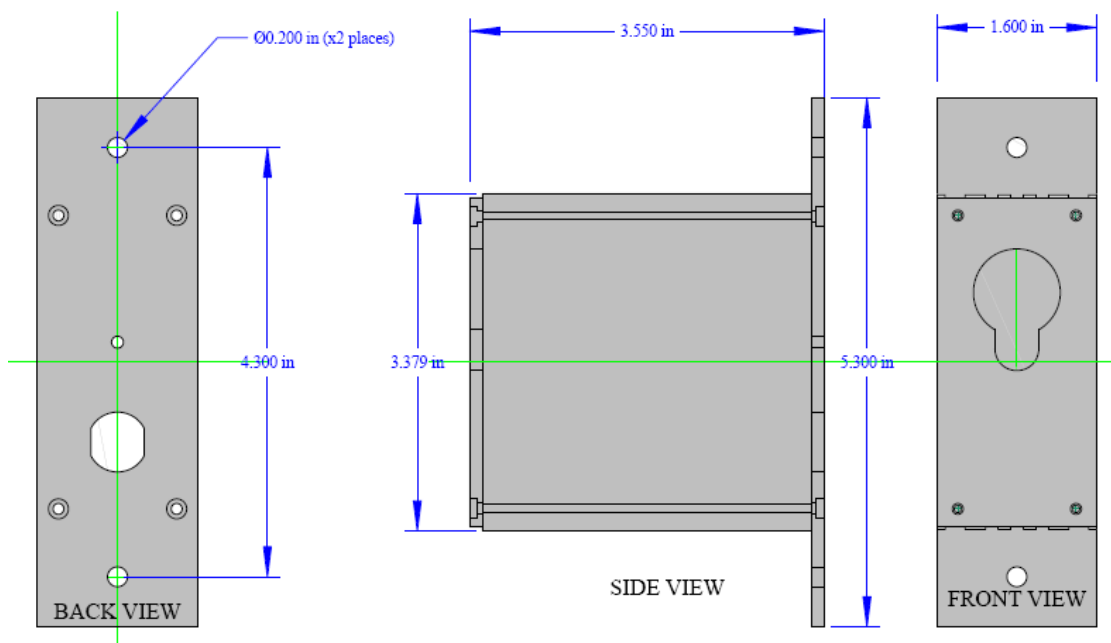

NOTICE

The UV LED “on” time is controlled by the user and should be minimized as described in this Instruction to achieve maximum life. For this reason, the LED is not covered by the manufacturer’s warranty.

EMX Industries Incorporated warrants all products to be free of defects in materials and workmanship for a period of two years under normal use and service from the date of sale to our customer. This warranty does not cover normal wear and tear, abuse, misuse, overloading, altered products, damage caused by incorrect connections, lightning damage, or use other than intended design.

There is no warranty of merchantability. There are no warranties expressed or implied or any affirmation of fact or representation except as set forth herein.

EMX Industries Inc. sole responsibility and liability, and the purchaser’s exclusive remedy shall be limited to the repair or replacement at EMX Industries option of a part or parts found not conforming to the warranty. In no event shall EMX Industries Inc. be liable for damages, including but not limited to damages resulting from non-conformity, defect in material or workmanship.

Effective date: January 1st, 2002





4564 Johnston Parkway
Cleveland, Ohio 44128
United States
www.emxinc.com

Technical Support: (216) 834-0761
E-mail: technical@emxinc.com

Sales: (216) 518-9888
Fax: (216) 518-9884
E-mail: salesupport@emxinc.com

Revision 2.0
4-6-2020